

# INSTRUCTIONS AND TIPS FOR THE INSTALLATION OF THE HC 37.53 MODEL CINEMA MIRROR

## GENERAL RECOMMENDATIONS FOR ASSEMBLY AND INSTALLATION



1

### CONSIDERATIONS

Cinema Mirror is an active optic set to be installed in false ceilings hiding the projection equipment, and that through a pulsation it opens a floodgate of 335x335 mm., allowing the projection of the image, thanks to its two mirrors, without causing the trapeze effect on the image. For that, Cinema Mirror and the screen must be in the same plane or with a difference from 0 to 12 cm. (Fig. 1).

Always be sure to perpendicularly set the projected light with the projection screen, any difference may negatively affect the image (Fig. 2).

The optic mirrors of this equipment are protected by a plastic film to avoid accidents. Remove this film when it is indicated by this manual.

**Do not do so beforehand.**

figure 1

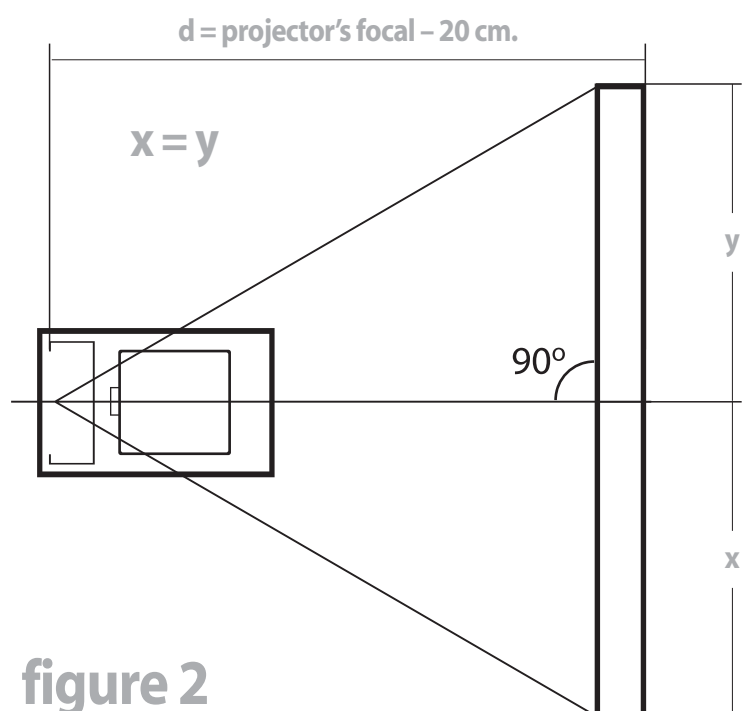

figure 2

# INSTRUCTIONS AND TIPS FOR THE INSTALLATION OF THE HC 37.53 MODEL CINEMA MIRROR

## GENERAL RECOMMENDATIONS FOR ASSEMBLY AND INSTALLATION



### 2

## BEFORE USING FOR THE FIRST TIME

Before proceeding to the installation and manipulation, read carefully this manual and follow conscientiously all the warnings and cautions that are described.

### GENERAL RULES

The equipment should be installed by installers specialized in public locations. Install and protect the line in accordance with the low-tension electrical technical regulations, as well as the MIE-BET-025 complementary technical instructions, "Installations in locations of public concurrence". The equipment should be connected to ground protection.

All the required electric works of this equipment should be carried out by electricians, qualified electronics or competent people according to the electrical technical regulations of each country.

The alimentation requires an automatic bipolar switch with **MINIMUM** 3 mm separation between contacts.

**Flammable materials must not be placed within a radius of 1 meter of the equipment** (see instruction manual of video projector to be installed).

Secure and protect the alimentation cables and hoses, gear, material, etc. in such a way that they are not near: moving parts or heat sources.

The equipment must be installed in the ceiling at a distance so that it is not within arms reach of a person. Secured above the site itself or on a metallic bracket strong enough to hold the weight of the equipment plus the image projector.

The equipment operation is: for interior use in a false ceilings.

The operating position is horizontal with the hatch facing downward.

The equipment will not be accessible during operation, before accessing the means of connection or the inside of the equipment, all electrical alimentation circuits of the equipment must be disconnected.

In the event of any questions, contact the Technical Service or your distributor.

### SAFETY

The equipment should be examined every 90 days, the structure fasteners, movable parts, mechanical cables, electrical parts, etc. should be checked and lubricated if necessary.

Do not install this unit in an unstable place. Do not alter neither modify this unit. Do not use this unit in a bathroom neither near liquids or inflammable gases. Do not connect the unit to an electric tension different from the one specified. Do not force the storm door in their opening or closing journey, since the mechanics of the motor could be seriously damaged.

# INSTRUCTIONS AND TIPS FOR THE INSTALLATION OF THE HC 37.53 MODEL CINEMA MIRROR

## GENERAL RECOMMENDATIONS FOR ASSEMBLY AND INSTALLATION

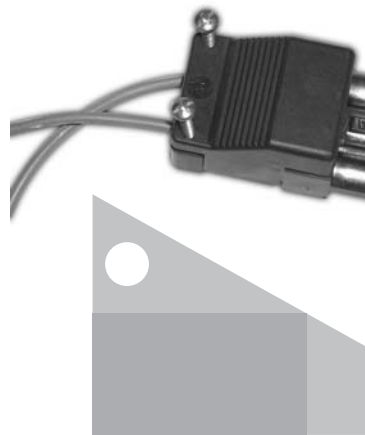
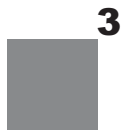

1,5 meters

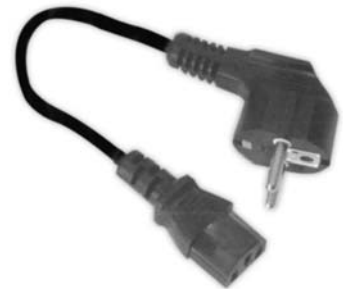

### INCLUDED ACCESSORIES

- Connection Cable 230 V.A.C.
- Connector for push-button (Push-button not included)
- Graded plate
- User Manual

### DEFINITION AND FUNCTION OF COMPONENTS

1 Variable position table

2 Position control lever of the active lens

3 Protection case of the electric equipment

4 Protection case of the mechanic equipment

5 Connection of the pushing-button and connection 230 VAC

6 Passive lens

7 Active lens

8 Closing connecting rod and parallelism

9 Leveling supports of variable height

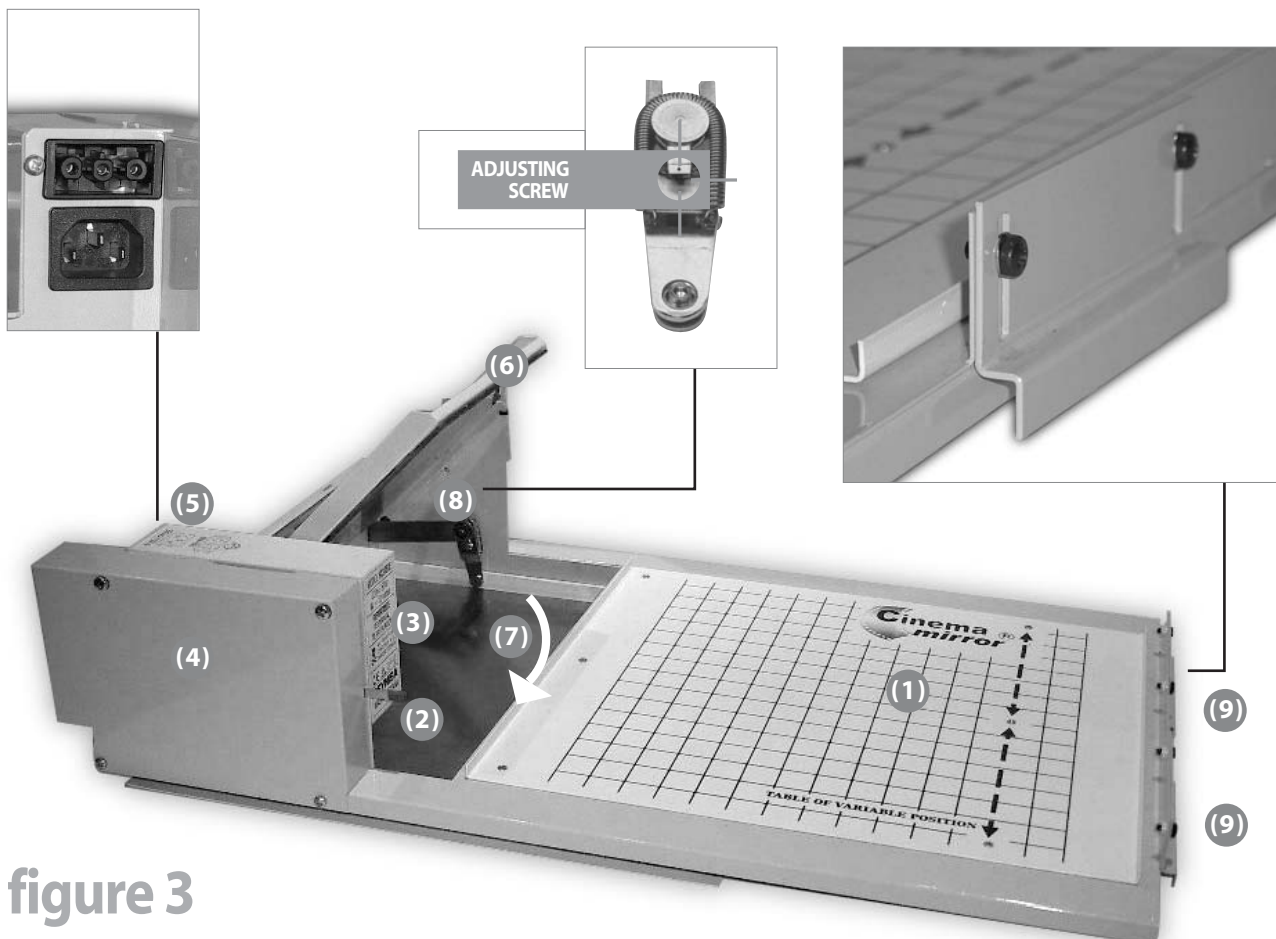

figure 3

# INSTRUCTIONS AND TIPS FOR THE INSTALLATION OF THE HC 37.53 MODEL CINEMA MIRROR

## GENERAL RECOMMENDATIONS FOR ASSEMBLY AND INSTALLATION



### INSTALLATION

#### PROCEDURE

**4**

Cinema Mirror has been built with the knowledge of technical ceiling features. For this reason, it has leveling supports (see Fig. 3 Detail 9) that adapt to the "T" ceiling profiles and allow you to install it without the use of tools.

If the ceiling is made of plaster, wood, glass, etc. and it does not have profiles, adapt a HC 635 model ceiling frame kit. An aluminium profile designed to adapt ceilings to Cinema Mirror and give access to the interior of the ceiling (see accessory page). Order it from your distributor.

#### BEFORE PROCEEDING TO INSTALL

The area where Cinema Mirror will be installed, next to the projection equipment, will support an extra weight. Reinforce the perimeter next to the installation area (Fig. 4) with the accessories recommended by the manufacturer.

#### CHOOSE THE PLACE OF THE INSTALLATION

The projectors do not have the same focus distance. If you do not know the optic data of the projector ready to be installed proceed as follows.

Place the projector on a table. Connect the electric current to the projector and switch on the projection equipment. Leave it for a few minutes so that the projector reaches its maximum brightness.

Keeping the zoom control in the maximum opening, bring the equipment closer to, or move it further away from the test wall that you have chosen until obtaining the desired screen - image width. In this case, measure the distance between the lens and the image.

Put the zoom in the minimum opening, and move the projector away until obtaining the same screen width than the obtained in the previous paragraph, and measure the distance between the lens and the image.

Calculate the focal distance with the following formula:

$$\text{Average optic center} = \frac{\text{maximum zoom distance (cm)} + \text{minimum zoom distance (cm)}}{2}$$

The average optic centre determines the distance and the place to install the projector and in consequence Cinema Mirror.

You can get bigger precision if you deduct 20 cm of the journey from the projector lens to the active lens.

figure 4

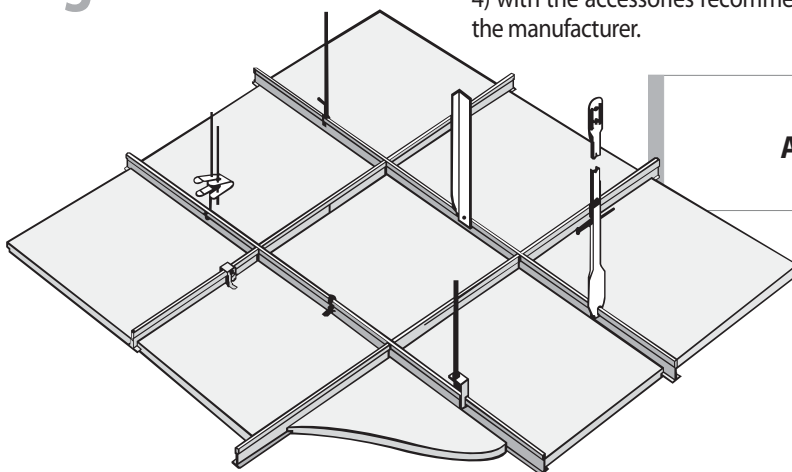

# INSTRUCTIONS AND TIPS FOR THE INSTALLATION OF THE HC 37.53 MODEL CINEMA MIRROR

## GENERAL RECOMMENDATIONS FOR ASSEMBLY AND INSTALLATION

### INSTALLATION



#### UNPACKAGING AND PROCESS OF ASSEMBLY



Open the box of the Cinema Mirror and take out the protection butt plates. Take out the plastic covers. Take out the rubber of protection of the floodgate of the active mirror.

Place a fabric table cloth on a board, table, bench, etc. to protect and take care of the paintwork on the equipment gate. Separate the bevel from the gate and leave it ready to be installed later in the ceiling finish. Leave Cinema Mirror on the table cloth.

Projectors do not always have the optic in the same place; it can be to the left, centred, or to the right.

For this reason, Cinema Mirror is equipped with a tray called **variable position table** (Fig. 5).

The variable position table has 5 positions: **1** centred, **2** moved to the left, **3** moved to the right, **4** turned 180° and centred, and **5** turned 180° and to the right.

Remove the 6 screws that secure the table to the Cinema Mirror chassis.

Secure the variable position table, with its screws, in the best place so that the projector rests on its support feet.

Place the projector on the variable position table horizontally centred relative to the passive mirror. This will be its working place.

#### ADJUSTMENT OF THE PASSIVE MIRROR

To centre in height the passive mirror, (Fig. 3 detail 6), in relation to the lens of the projector, remove the screws that hold it to the chassis and move them up and down so that the centre of the mirror stays at the centre of the lens of the projector. Tighten firmly, but not too strong, the axis of the mirror to the holes of the chassis, to make possible an ulterior adjustment of the axis.

Place the graded plate supplied with the equipment on the Cinema Mirror profile (Fig. 6).

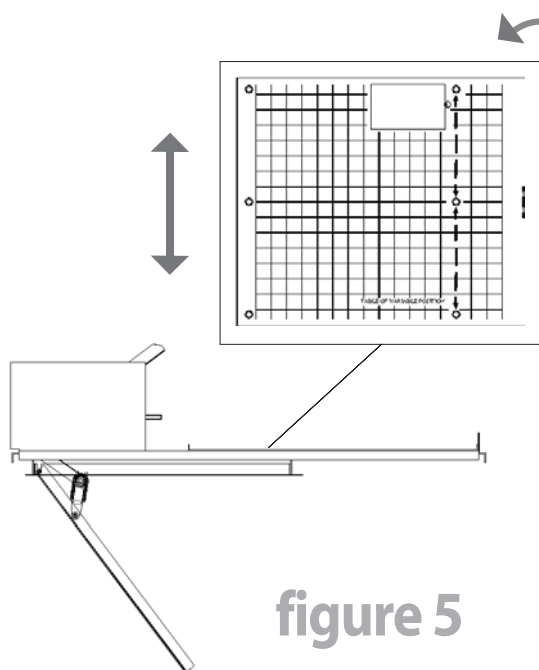
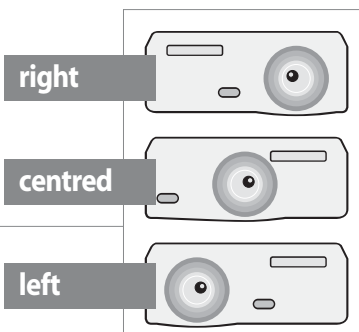

figure 5

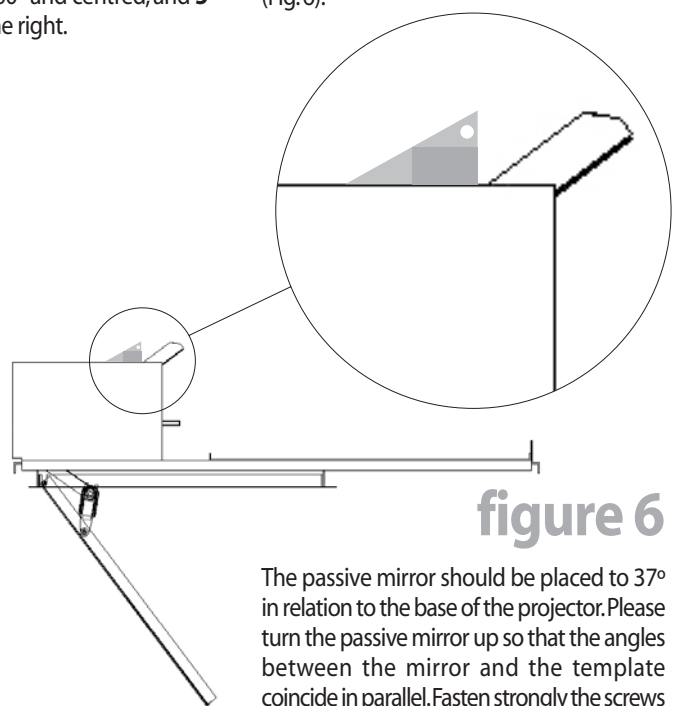

figure 6

The passive mirror should be placed to 37° in relation to the base of the projector. Please turn the passive mirror up so that the angles between the mirror and the template coincide in parallel. Fasten strongly the screws of the axis of the passive mirror.

# INSTRUCTIONS AND TIPS FOR THE INSTALLATION OF THE HC 37.53 MODEL CINEMA MIRROR

## GENERAL RECOMMENDATIONS FOR ASSEMBLY AND INSTALLATION



## NOW CINEMA MIRROR IS READY TO BE INSTALLED IN THE CEILING

### INSTALLATION IN THE CEILING

**6**

Remove the plate that coincides with the projector focal distance from the technical ceiling and leave it aside for its use later on the final finish of the ceiling.

If the ceiling is made of stucco, wood, glass etc, install the HC 635 ceiling frame kit beforehand; Four "T" profiles to be assembled with its accessories so as to facilitate the perfect decorative finish of the ceiling.

Insert the Cinema Mirror with the optic mirrors facing the place where the projection screen will be installed. Place the chassis onto the "T" shaped profiles of the technical roof, (or the HC 635 frame Kit), and make coincide the 2+2 leveling supports of the chassis (Figure 3, detail 9) with the technical roof profile.

**IF THE INSTALLATION IS NOT EQUIPPED WITH A WORKABLE TECHNICAL CEILING, BUILD YOUR OWN SPACE USING THE HC 635 MODEL CEILING FRAME KIT.**  
(see accessory page)

Now the height of the chassis can vary and can be levelled with the roof. To level them, please unfasten the screws of the leveling supports which holds the chassis and screed the latter to the same height of the surface of the roof. Fasten again and strongly the screws.

**ATTENTION PLEASE! The motor system (active door) is not prepared to carry heavy loads, as for example, parts in wood, cork, glass, etc., that one might want to install on the door as decoration items.**

**If you desire this, try to modify the finish, by painting or imitating the painting by means of a very thin foil, to be able to integrate the finish of the door of the Cinema Mirror to the roof decoration in which it is installed.**

Install the projector on the variable position table.

- Place the projector optic as close to the passive mirror as possible.
- Place the projector optic centred relative to the passive mirror.

## ELECTRICAL CONNECTION

Connect a pushing-button (not included, of 1A 230 V.A.C.) to the supplied entrance connector. Insert the connector of the pushing-button in the Cinema Mirror.

Connect the power source cable to the electric net and to protect with a bipolar

switch (not supplied) with separation among contacts of 3 mm. (ELECTRIC DIAGRAM)

Connect the video, DVD, PC, control signals, etc, following the instructions of the videoprojector maker. Secure the cables with flanges or plastic loops, (available in shops),

checking that they do not restrict the access and movement of the chassis on the technical ceiling "Ts" or supports. Move the cables away from the area to facilitate the later handling of the videoprojector: cleaning, lamp replacement, etc.

### ELECTRIC CURRENT INPUT

PHASE (L1) BROWN  
EARTH (⊕) YELLOW / GREEN  
NEUTER (N) BLUE

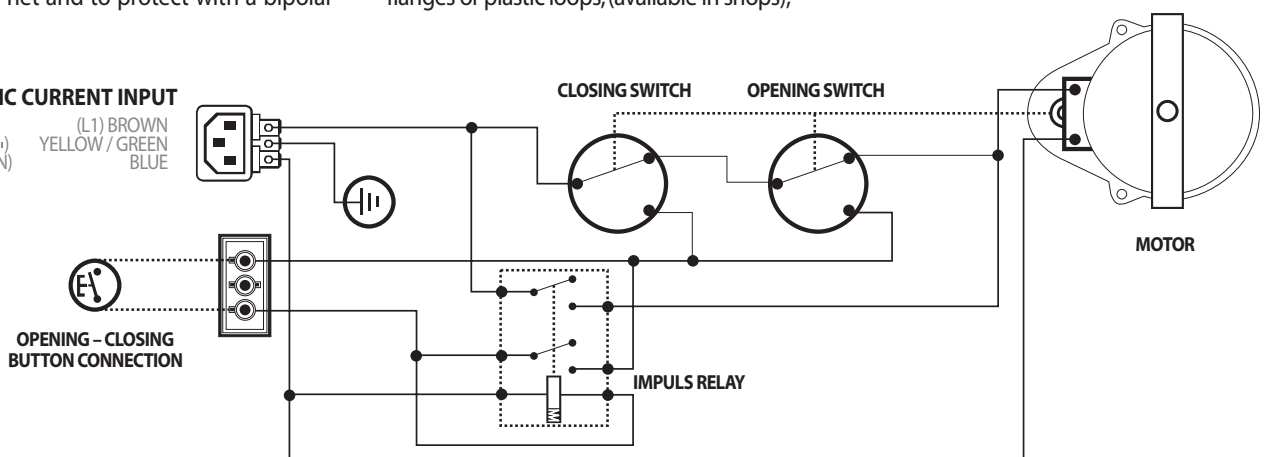



# INSTRUCTIONS AND TIPS FOR THE INSTALLATION OF THE HC 37.53 MODEL CINEMA MIRROR

## GENERAL RECOMMENDATIONS FOR ASSEMBLY AND INSTALLATION



## HOW TO ADJUST THE IMAGE TO THE SCREEN

### ATTENTION – DANGER !!

Take out the rubber that blocks the door during the transport (if you have not already made it), before triggering the movement pushbutton of the active mirror gate, make sure that there are no obstacles hindering its opening or closing. Do not make any effort to stop or help the active mirror gate in its path, the mechanics of the motor can be seriously damaged and the warranty of the product will be lost.

If you observe any defect, this may be due to the handling or lack of care during transport of Cinema Mirror. Contact your distributor's technical service.

Activate the button for opening or closing (not included) on the Cinema Mirror. The motor of the active mirror will be put into operation.

Remove the film that protects the optic mirrors during transport and pre-installation.

Switch on the projector and wait a few minutes so that the projector reaches its maximum brightness.

The light or image thrown by the projector through the active mirror determines the place where the projection screen should be installed.

Remember that you can work on the projector zoom to fix the screen width.

Install the projection screen guided by the light spectrum thrown by the projector. If you use a screen with black side margins, the image will be better profiled; as television sets do in their cathode ray tubes.

### INSERT A VIDEO OR PC SIGNAL IN THE INSTALLED PROJECTOR

The control lever of red color regulates the position and opening of the active mirror (Fig. 3 detail 2) and consequently, the projection height on the screen.

- Place the control lever on the upper part.
- Activate the motor with the installed pushbutton.
- Observe the image that is projected on the screen. To lower the image the control lever should be moved downward. The motor activates and positions the active door as desired.
- Repeat this operation until reaching the desired image height.

### ATTENTION.

If the whole image is not represented on the projection screen, this may be due to the fact that:

- The projector zoom is closed.
- The projector is very near the passive mirror.
- The active mirror is excessively closed.

Correct these differences.

The image may not be parallel with the projection screen base due to height differences between the place of installation of the screen and that of the projector (Fig. 7A).

In the connecting rods that move the active mirror, (Fig 3 detail 8) there is a connecting rod-active mirror regulation screw that corrects the defect. If you want to lift the image, move the connecting rod screw of the place affected upwards. (Fig. 7B)

Remember the adjustment elements that you have to obtain a cinema image.

1. - Projector zoom and focus.
2. - Vertically adjustable feet, in the projector.
3. - Trapeze correction, manual, automatic or electronic, in the projector.
4. - Passive mirror turn.
5. - Active mirror movement
6. - Horizontal image control in the connecting rods.
7. - Left / right movement of the projection screen (only some makers)
8. - Regulation of the height extension of the projection screen.

figure 7A



figure 7B



7

# INSTRUCTIONS AND TIPS FOR THE INSTALLATION OF THE HC 37.53 MODEL CINEMA MIRROR

## GENERAL RECOMMENDATIONS FOR ASSEMBLY AND INSTALLATION



### FINAL FINISH OF THE CEILING



figure 8

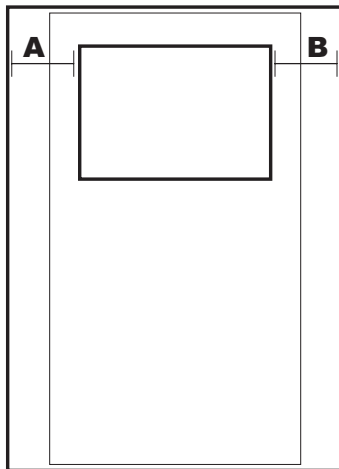

Once we are definitively satisfied with the image obtained, we will proceed to close the ceiling with the same material used by the maker of the technical ceiling. If you use other materials, try to use materials with a very low weight. Consult the possibilities of painting or masking of the material used for a correct simulation with the original ceiling.

**ATTENTION PLEASE!** The motor system (active door) is not prepared to carry heavy loads, as for example, parts in wood, cork, glass, etc., that one might want to install on the door as decoration items.

If you desire this, try to modify the finish, by painting or imitating the painting by means of a very thin foil, to be able to integrate the finish of the door of the Cinema Mirror to the roof decoration in which it is installed.

Take the measurements in which the gate was located with the frame, measurements A and B (Fig 8). Mark the measurements A and B on the technical ceiling plate (60x60cm), (or replacement material).

Place the bevel on the marks A and B, and draw the contour lines. With a cutting tool remove the space that must be occupied by the gate.

The installer should locate his working position in the square of the technical ceiling plate, adjacent to the Cinema Mirror installation.

Move the Cinema Mirror-projector set as much as is necessary to install the modified technical plate.

Place the Cinema Mirror-projector set in the space chosen.

Lightly press the bevel pins outwards and adjust them to the gate.

Check the light-image on the screen.

Provide the finishing touches to the ceiling finish according to the characteristic requirements of the space.



### MAINTENANCE

The mechanics and mobile parts of the equipment don't specify of a severe maintenance, but if it is convenient the application of a lubricant in the mobile parts, with a minimum periodicity of 90 days. Revise the electric installation and its connections, likewise revise the anchorage from the unit to the roof.

The optic lenses will clean with non abrasive cloths, using neuter soaps or simply with common water.



# INSTRUCTIONS AND TIPS FOR THE INSTALLATION OF THE HC 37.53 MODEL CINEMA MIRROR

## GENERAL RECOMMENDATIONS FOR ASSEMBLY AND INSTALLATION



## TECHNICAL SPECIFICATIONS

(dimensions in mm).

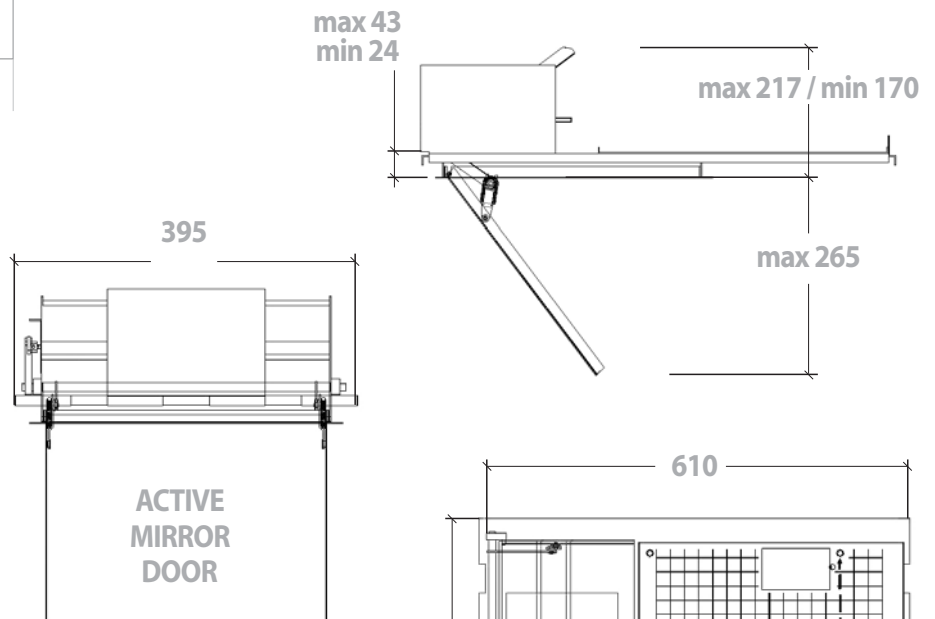

## TECHNICAL FEATURES HC37.53

<b>Supply:</b>	<b>Mod.E</b> 230 VAC / 50Hz.
<b>Power:</b>	<b>Mod.US</b> 115 VAC / 60Hz.
<b>Starter (push-button not included):</b>	10 W
<b>Noise level:</b>	Instantaneous / 1 A to 230 VAC
<b>False ceiling minimum height:</b>	< 15 dB
<b>Maximum height of floodgate slope:</b>	From 170 mm to 217 mm
<b>Mirror opening time:</b>	265 mm
<b>Motor reducer:</b>	30"
<b>Minimum dimension of the hole to embed:</b>	500/1
<b>Mechanical Dimensions (mm):</b>	335 mm x 335 mm
<b>Packed Dimensions (mm):</b>	<b>LONG</b> 625 / <b>WIDE</b> 395 / <b>HIGH</b> 170
<b>Max. weight admitted:</b>	<b>LONG</b> 680 / <b>WIDE</b> 460 / <b>HIGH</b> 240
<b>Net weight:</b>	5,0 Kg
<b>Gross weight with packing:</b>	8,2 Kg
	12,3 Kg

## OPTIONAL ACCESSORIES

### Frame Kit HC 635

Four aluminium sections, squares, screws, etc.. to build a frame that replace the technical ceiling outlines (Armstrong or similar), and gives a professional ending and support in plaster ceilings, wood ceilings, etc... With a professional ending as support on your **Cinema Mirror** installations.

<b>Inside Dimensions:</b>	597x597 mm
<b>Outside Dimensions:</b>	640x640 mm

